

Cold Atoms, Bose –Einstein condensation and Clocks

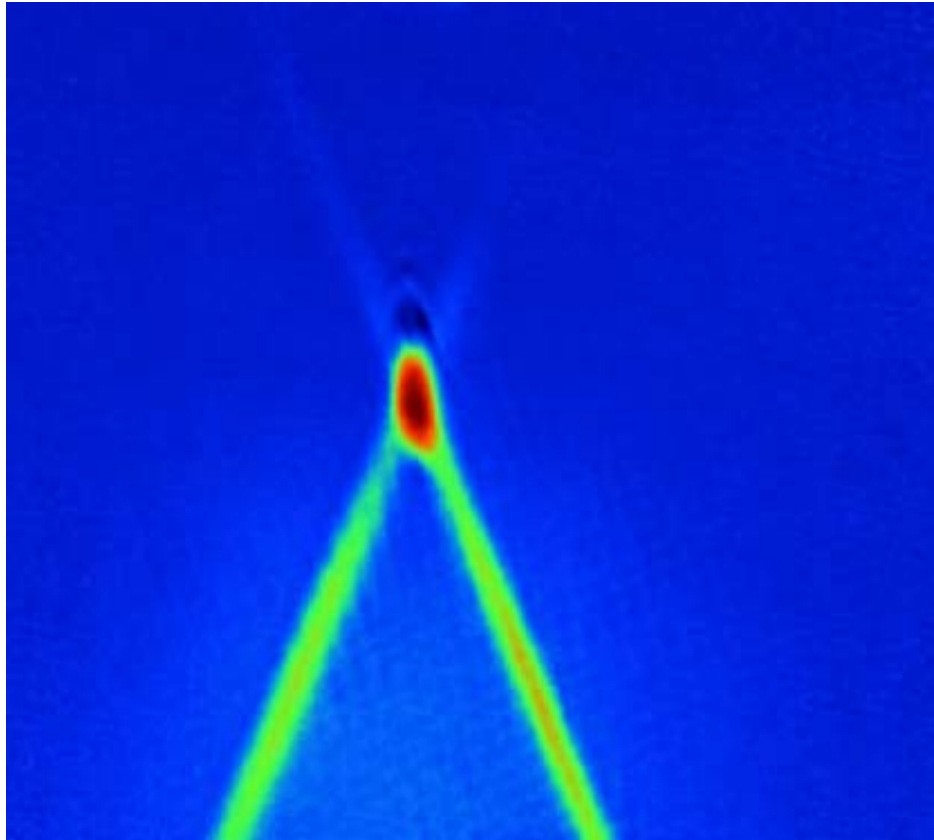

C. Salomon

Laboratoire Kastler Brossel, Ecole Normale Supérieure, Paris
BIPM summer school, July, 2003

<http://www.lkb.ens.fr/recherche/atfroids/tutorial/welcome.htm>

Outline of lectures

- **Lecture 1**
- Experiments with cold atoms
- Atomic beam slowing, optical molasses, traps
- Bose-Einstein condensation and applications
- **Lecture 2**
- Atomic clocks: basics
- **Lecture 3**
- Applications of atomic clocks

Temperature scale

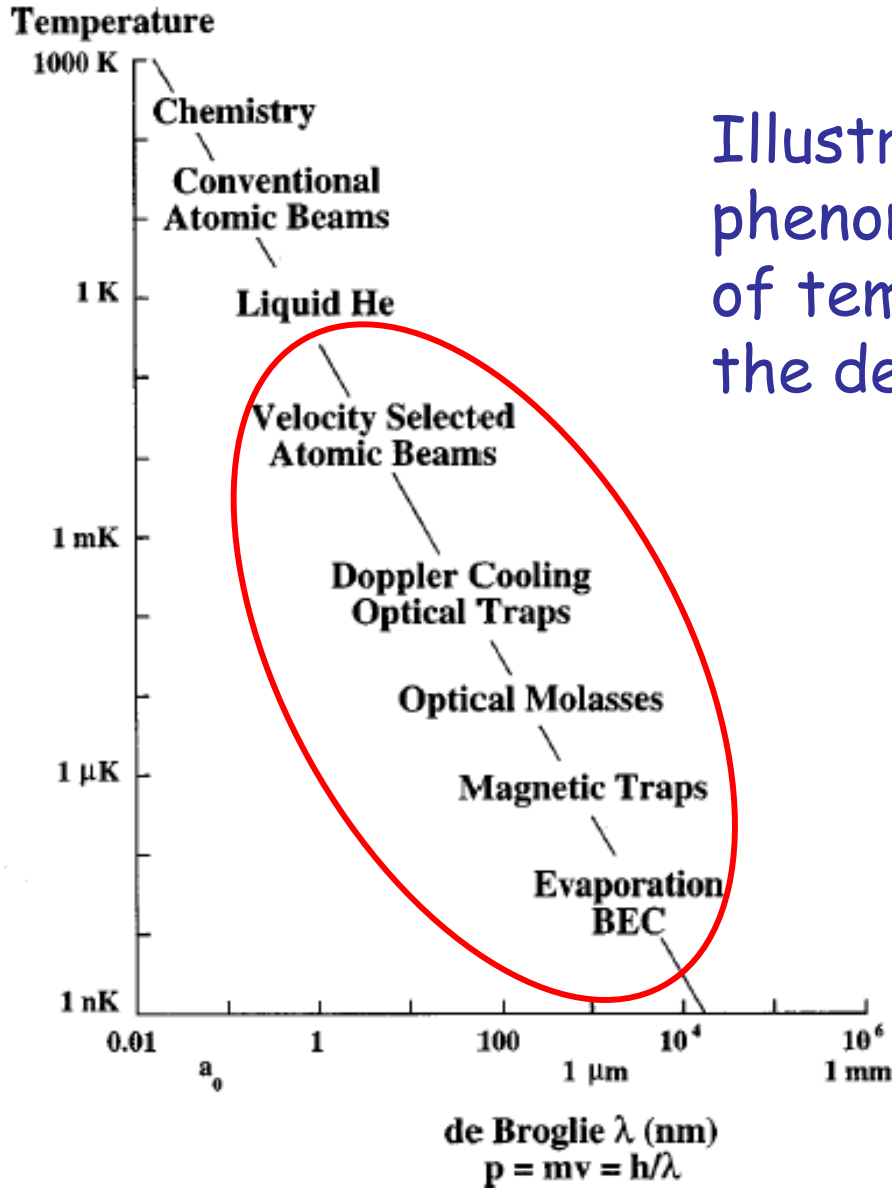

Illustrative plot of various phenomena along a scale of temperature plotted against the de Broglie Wavelength

Radiation Pressure and Atomic beam slowing

Resonance condition

$$\omega_L - k_L V(z) = \omega_A(z)$$

$$V^2(z) = V_0^2 - 2a_{\max} z$$

$$z_0 = V_0^2 / (2a_{\max})$$

inhomogeneous magnetic field

$$F(z, v) = \frac{\hbar k \Gamma}{2} \frac{s_0}{1 + s_0 + 4[\delta + kv - \mu' B(z)/\hbar]^2 / \Gamma^2}$$

$$s_0 \equiv I/I_0$$

$$I_0 = \frac{\Gamma \hbar \omega_0^3}{12 \pi c^2}$$

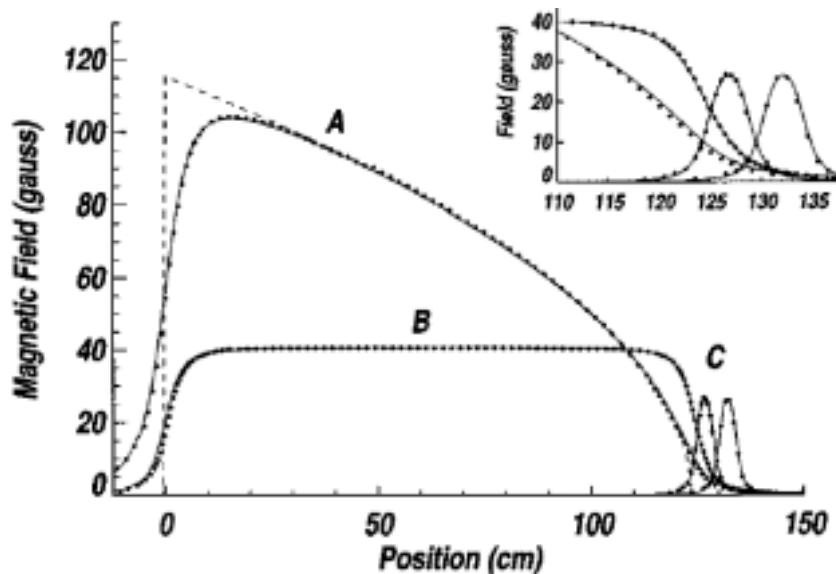

$$B(z) = B_b + B_p \sqrt{1 - z/z_s}$$

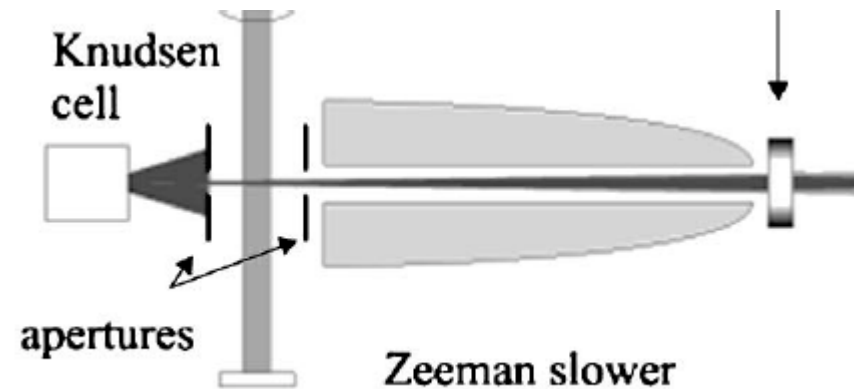

Atomic beam slowing (2)

- Chirped cooling

$$\omega_L(t) - k_L V(t) = \omega_A$$

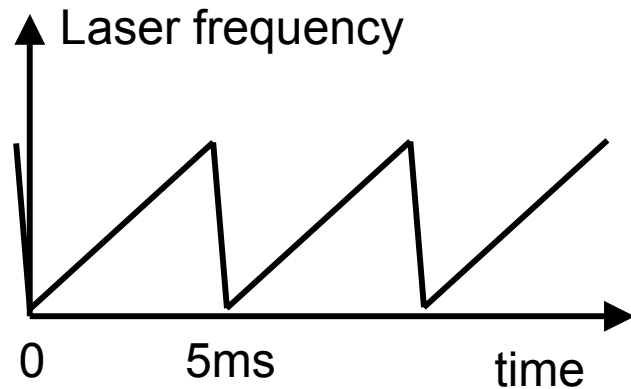

Extremely simple with diode lasers !

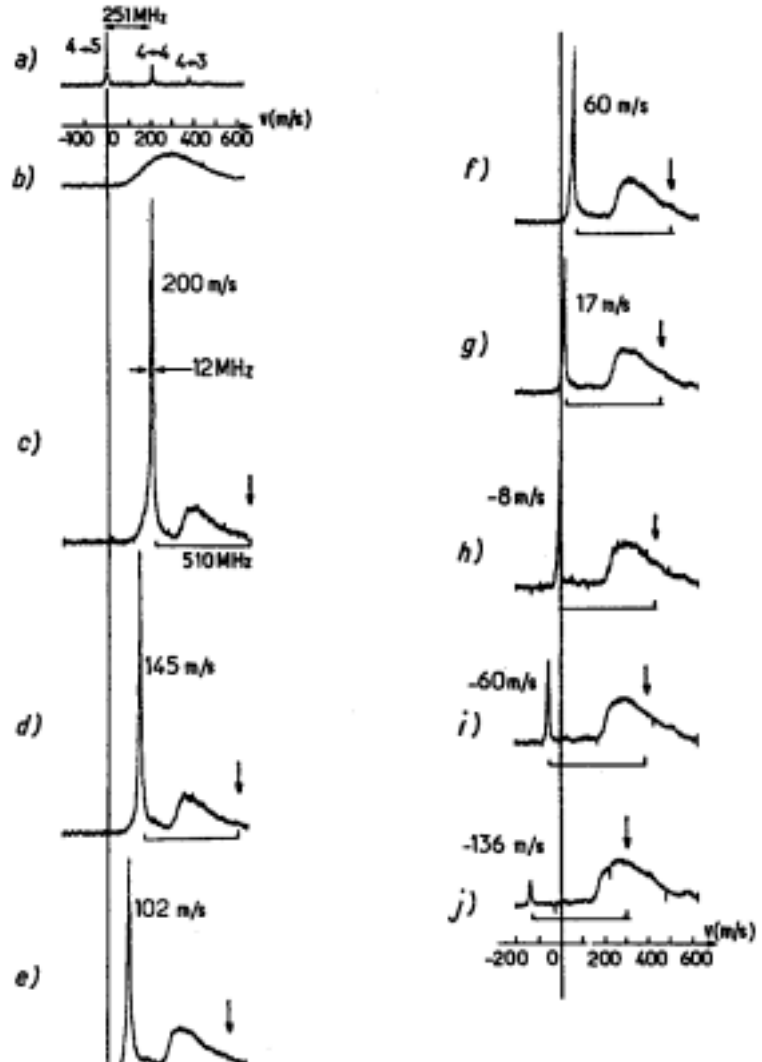

Doppler Cooling

Doppler effect

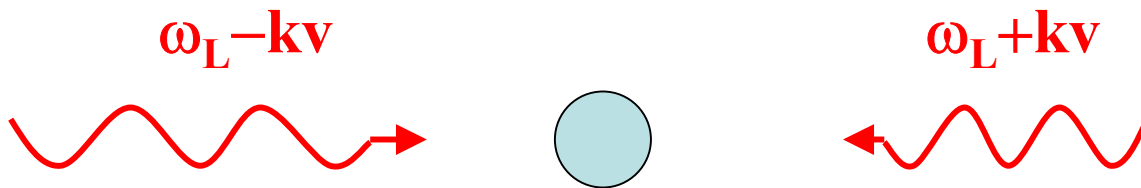
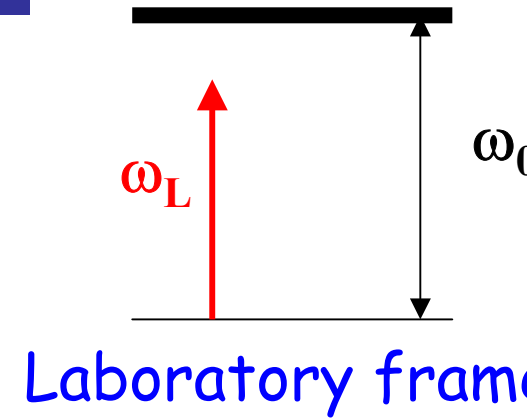
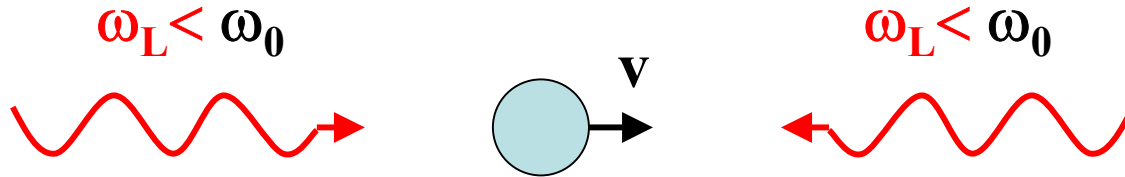

Atom frame

Absorption of the photon $\omega_L + kv$, followed by a spontaneous emission equiprobable in all directions of the space.

Act as: $\mathbf{F} = -\alpha \mathbf{v}$ (friction force) = $m d\mathbf{v}/dt$

Optical molasses



S. Chu, Scientific American, 174, 1992

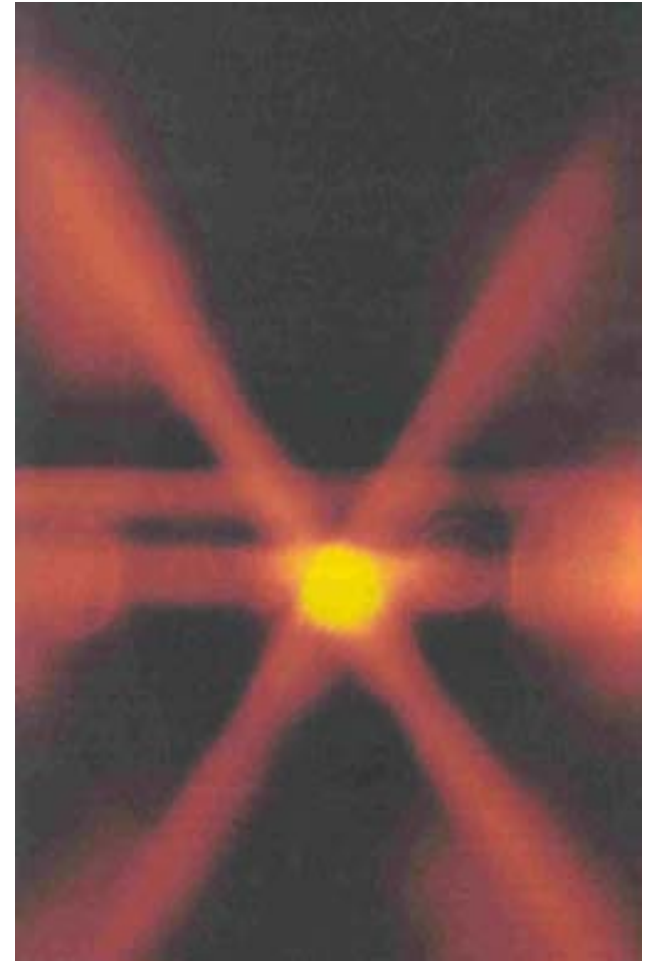

Na molasses

Temperature measurement

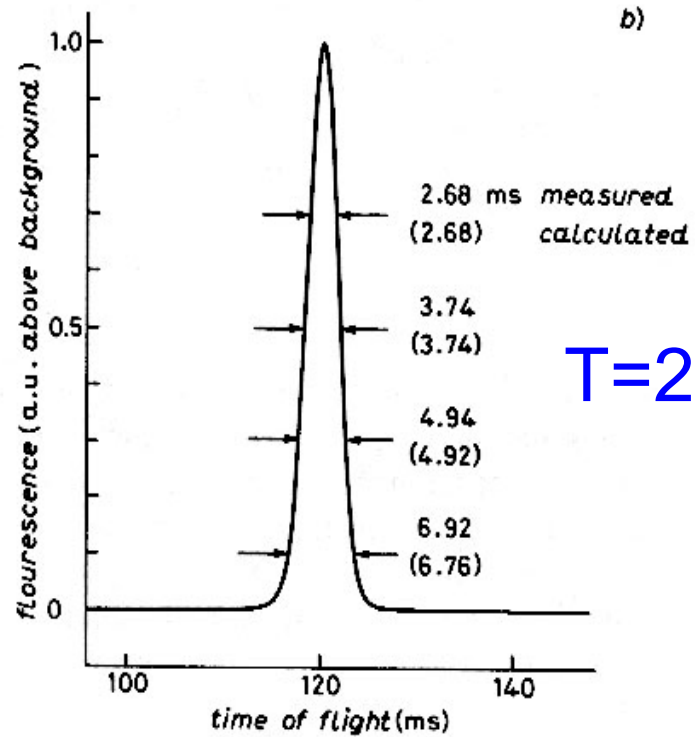
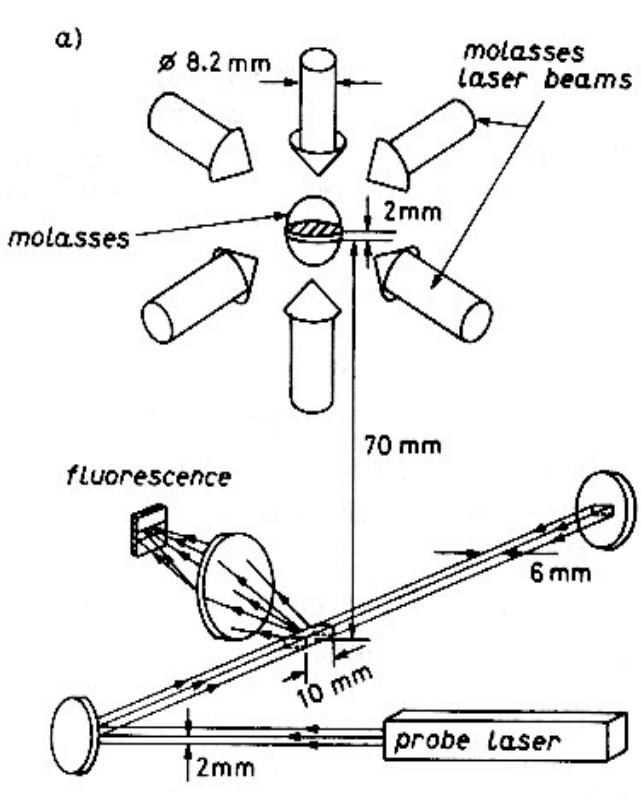

$T = 2.5 \mu\text{K}$

$$\frac{1}{2} k_B T = \frac{1}{2} M V_{rms}^2$$

$$V_{rms} = 12 \text{ mm/s}$$

Sisyphus cooling

J. Dalibard, C. Cohen-Tannoudji

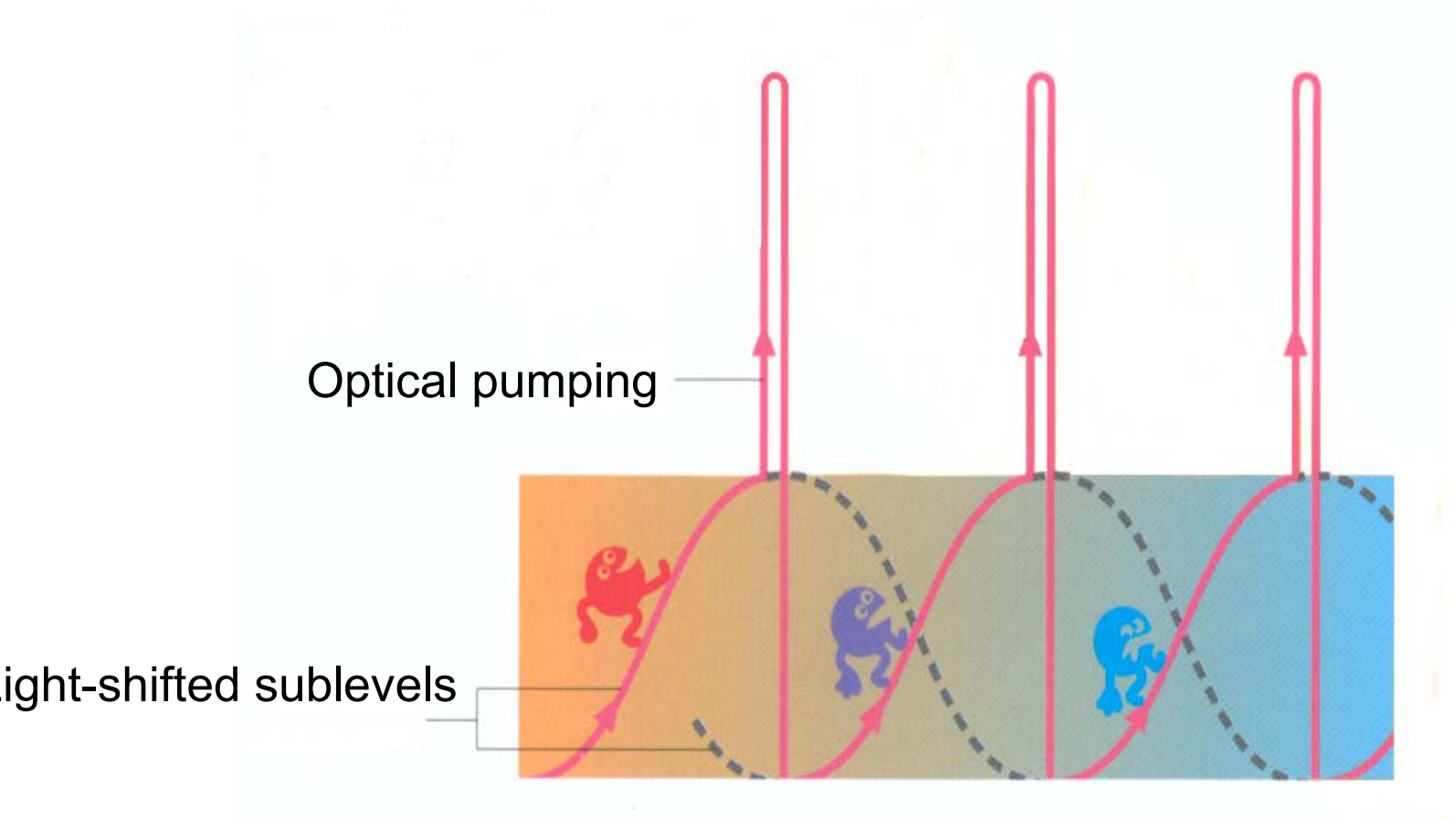

$$k_B T = U_0 / 4$$

Limit Temperature: about 10 times recoil energy

Test of Sisyphus cooling

$T \sim \text{Laser intensity/Laser detuning}$

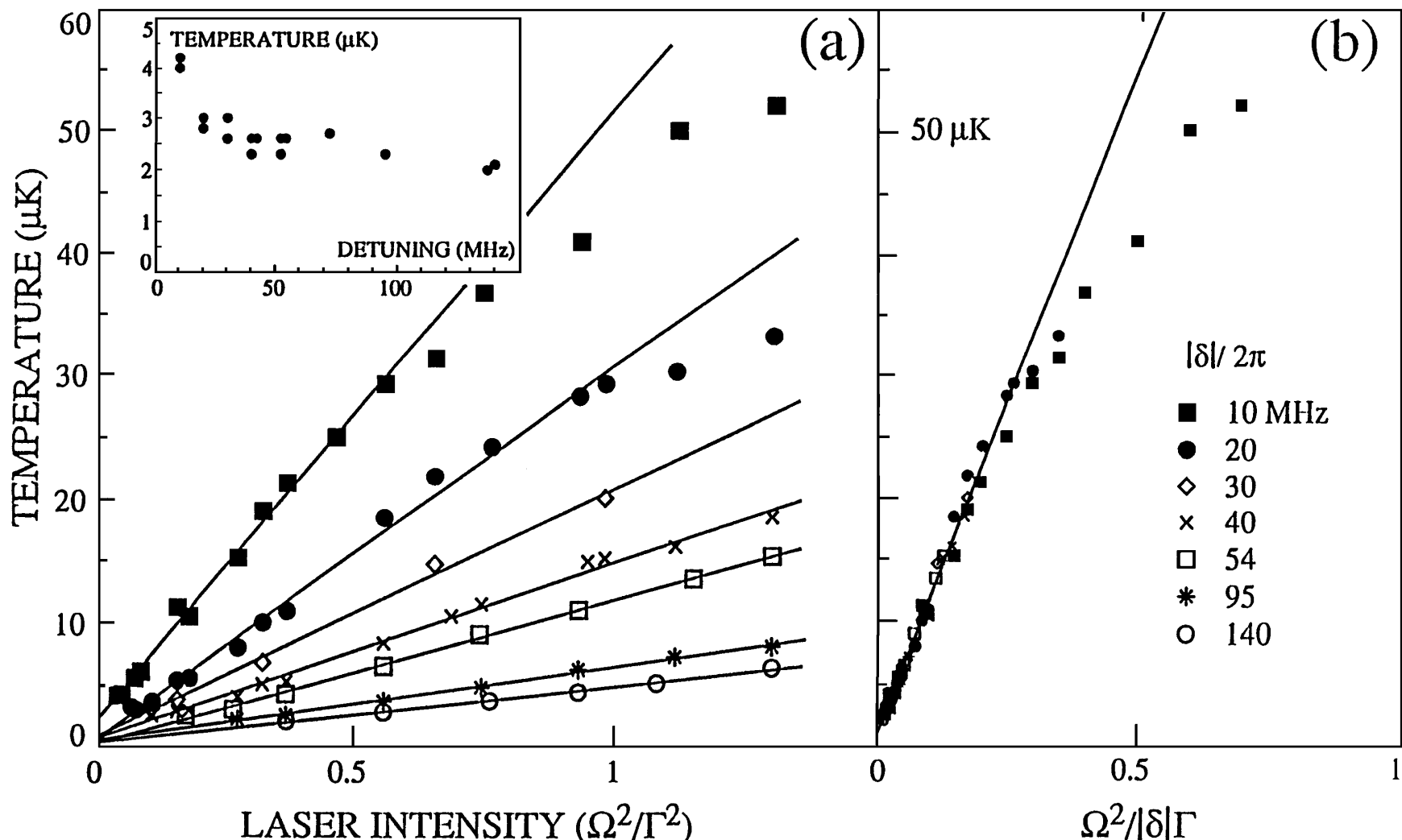

Magneto-optical trap

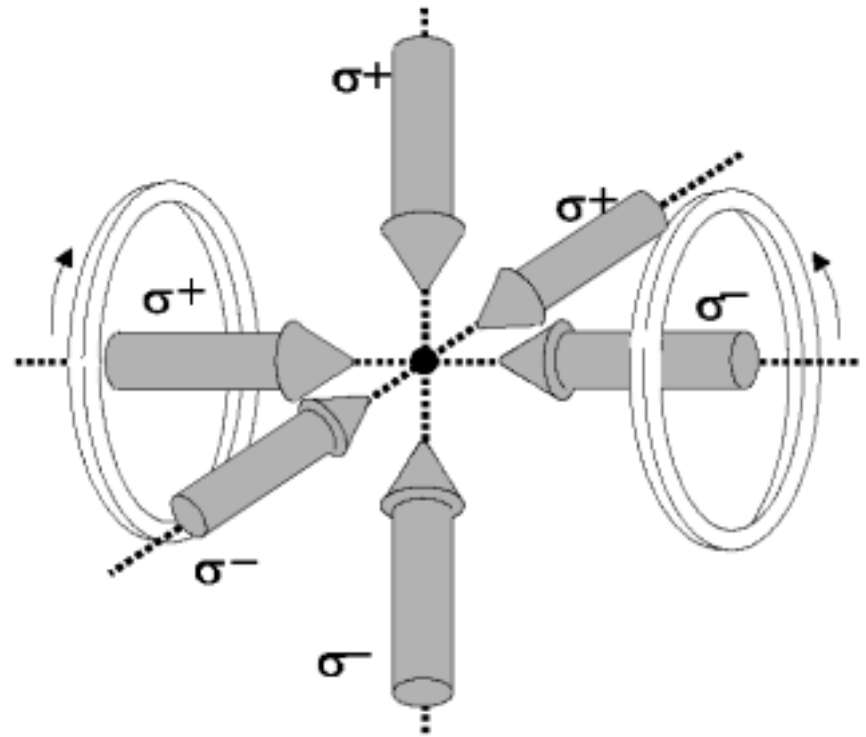
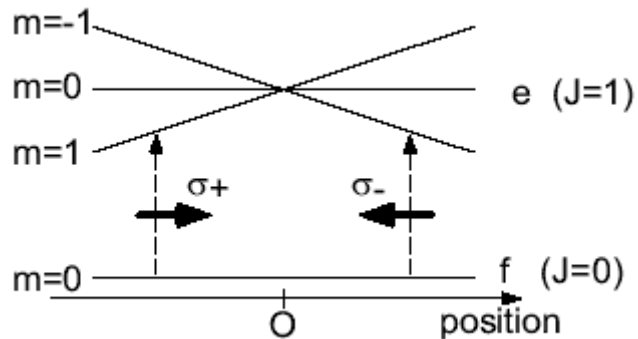

$$\mathbf{F} = -\alpha \mathbf{v} - \mathbf{k} \mathbf{r}$$



3D Molasses
Doppler effect

Trapping
Zeeman effect

$b' = 10 \text{ Gauss / cm}$
 $I = \text{a few mW per beam}$

Lithium magneto-optical trap

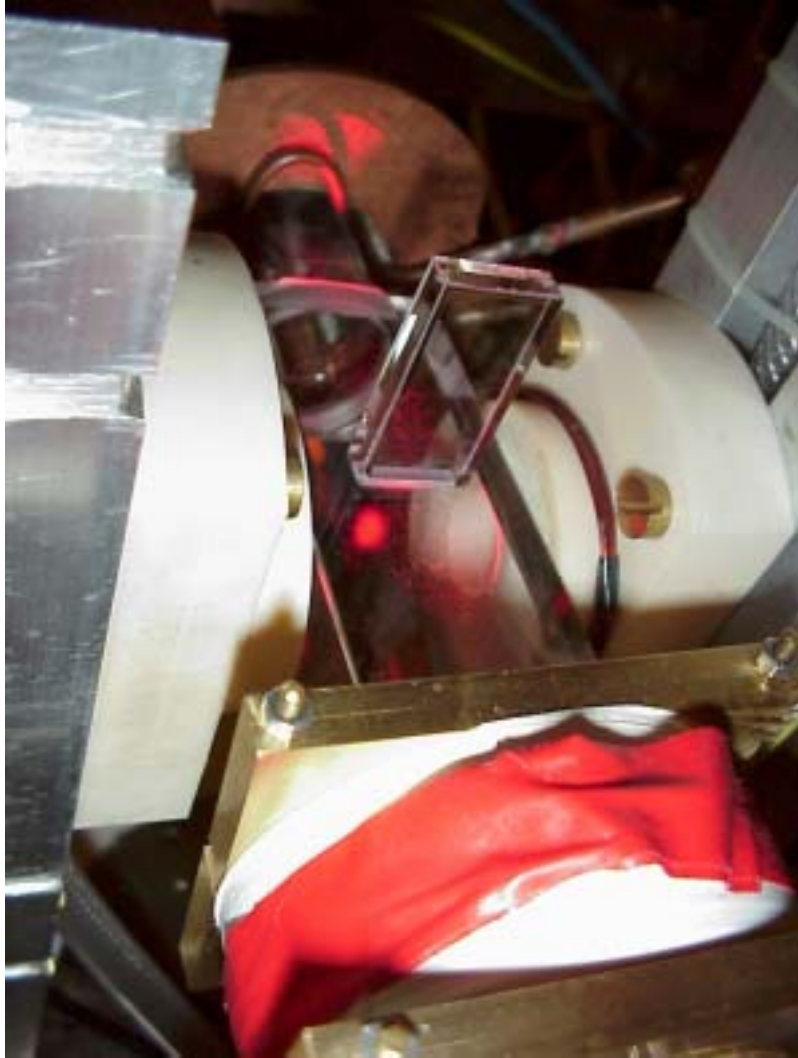

Trapping:

$$\vec{F} = -\vec{k} \cdot \vec{r}$$

In addition, cooling:

$$\vec{F} = -\vec{k} \cdot \vec{r} - \alpha \vec{v}$$

Doppler cooling

+ sub-doppler cooling

Considerable increase
in phase-space density:

$$n \lambda_{DB}^3 \approx 10^{-6}$$

Up to a few 10^{10} atoms

Density 10^{11} at/cm³

Optical bench for laser cooling

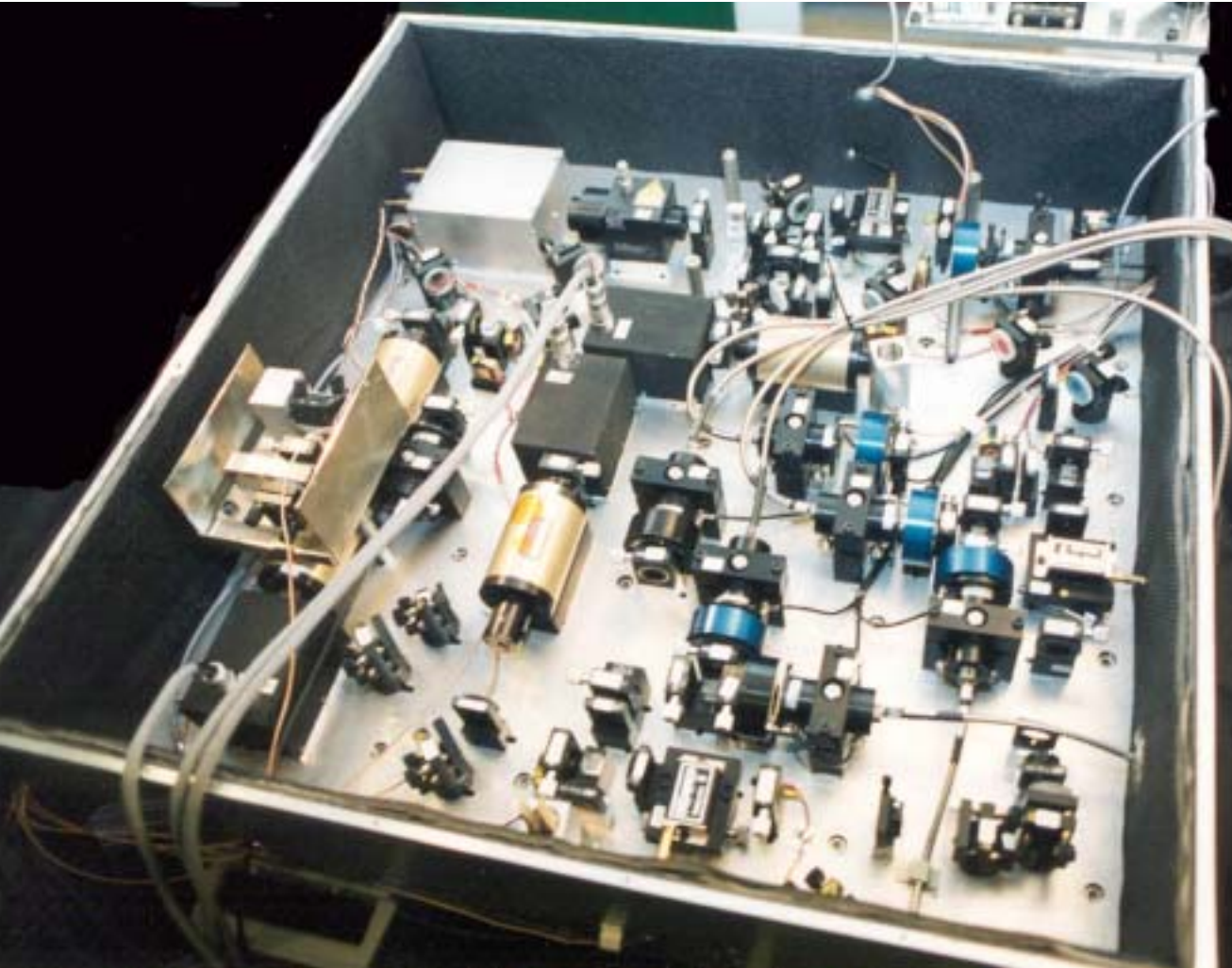

l'Observatoire
de Paris | SYRTE

PHARAO

Bose-Einstein Condensates: orders of magnitude



Dilute gas of atoms at temperature T
confined in harmonic potential :

$$V(\vec{r}) = \frac{1}{2} m \omega^2 r^2$$

Condensation threshold:

$$N = 1.202 \left(\frac{k_B T}{\hbar \omega} \right)^3$$

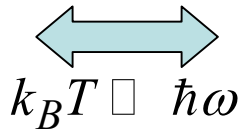

$$n_0 \lambda^3 = 2.612$$

$$\left\{ \begin{array}{l} n_0 : \text{central density} \\ \lambda = \frac{h}{\sqrt{2\pi m k_B T}} \end{array} \right.$$

Liquid helium :

$$10^{27} \text{ atoms/m}^3$$

$$n_0^{-1/3} = 10 \text{ \AA} \quad T \sim 1 \text{ K}$$

Gaseous condensate

$$10^{19} \text{ at/m}^3$$

$$n_0^{-1/3} = 0.5 \text{ \mu m} \quad T \sim 1 \text{ \mu K}$$

Magnetic trap

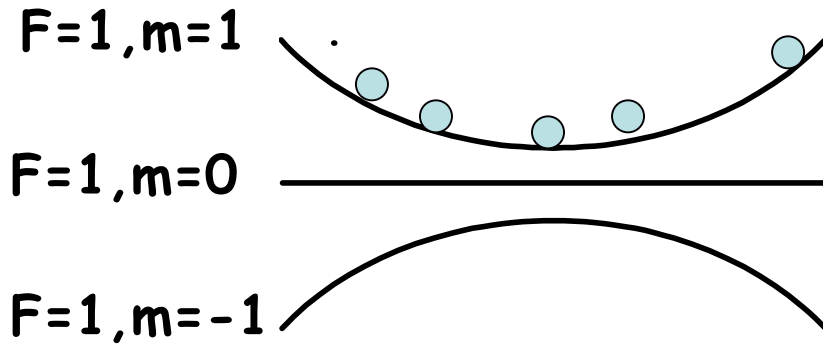

$$E = -\vec{\mu} \cdot \vec{B} = +|\vec{\mu}| |\vec{B}|$$

Maxwell's equations:

No max of $|\mathbf{B}|$ in vacuum

Local minimum of $|\mathbf{B}|$
+ spin polarisation

$$V = -|\mu| |\mathbf{B}|$$

Atoms cannot be magnetically trapped in the lower energy state.

Two-body inelastic collisions

Example: Ioffe-Pritchard trap

Trap depth 1 mK

Loaded with laser cooled atoms

Or cryo-cooled atoms (Harvard)

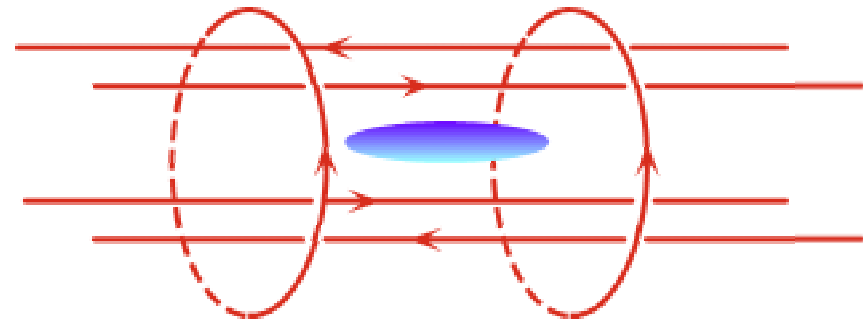

Evaporative cooling

- The only known method to reach quantum degeneracy
 - Remove hot atoms
 - Elastic collisions ensure re-thermalisation

$$\gamma_{elastic} / \gamma_{inelastic} \geq 150$$

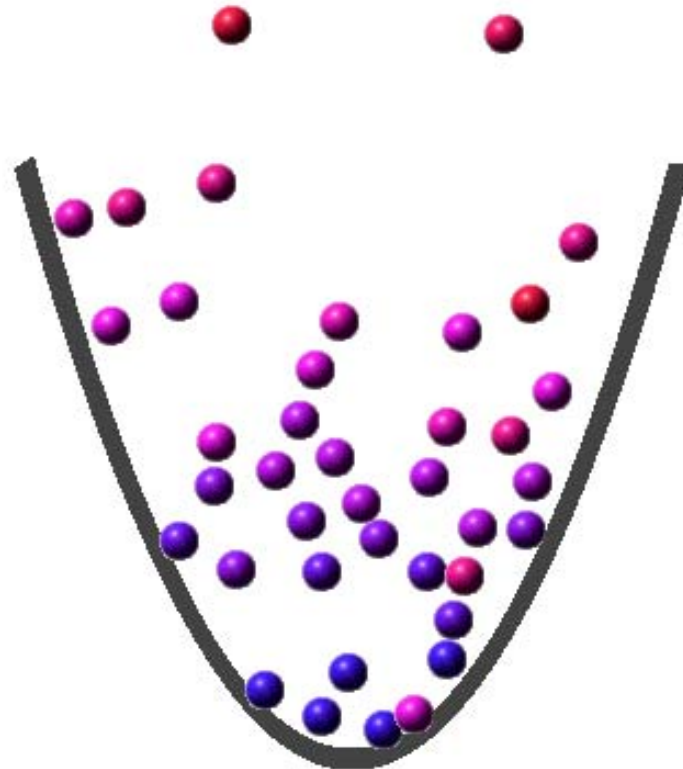

Evaporative cooling (2)

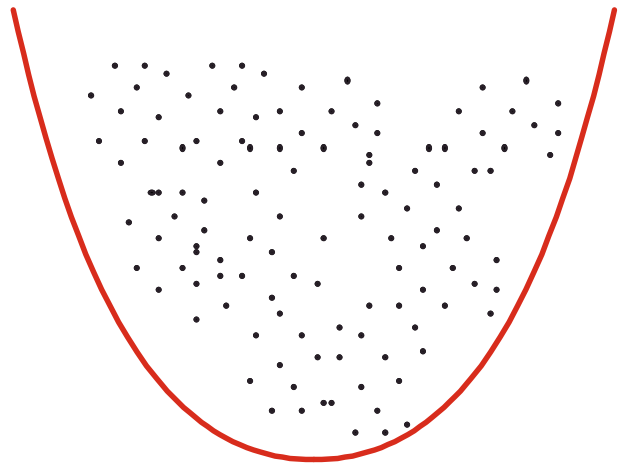

$$N \longrightarrow N / 100$$

$$T \longrightarrow T / 1000$$



Phase-space density $n\lambda^3$
multiplied by 10^7



Duration : 5 to 30 seconds, $N_f=10^5$ to 10^7 atoms, $T_f=0.2$ to $2 \mu\text{K}$

Imaging cold atomic clouds and condensates

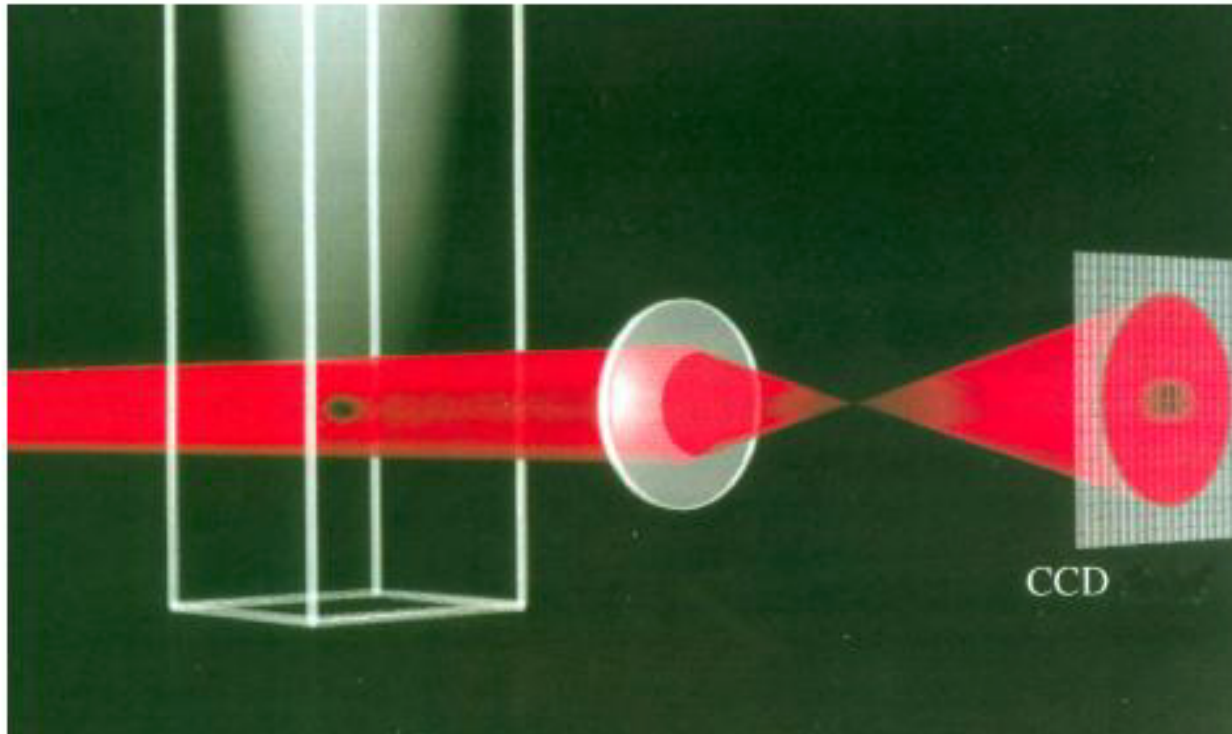

Absorption imaging

- 1) In situ measurement: spatial distribution in the trap
- 2) After time of flight expansion: velocity distribution

Bose-Einstein Condensation in Rubidium 87

JILA - Boulder

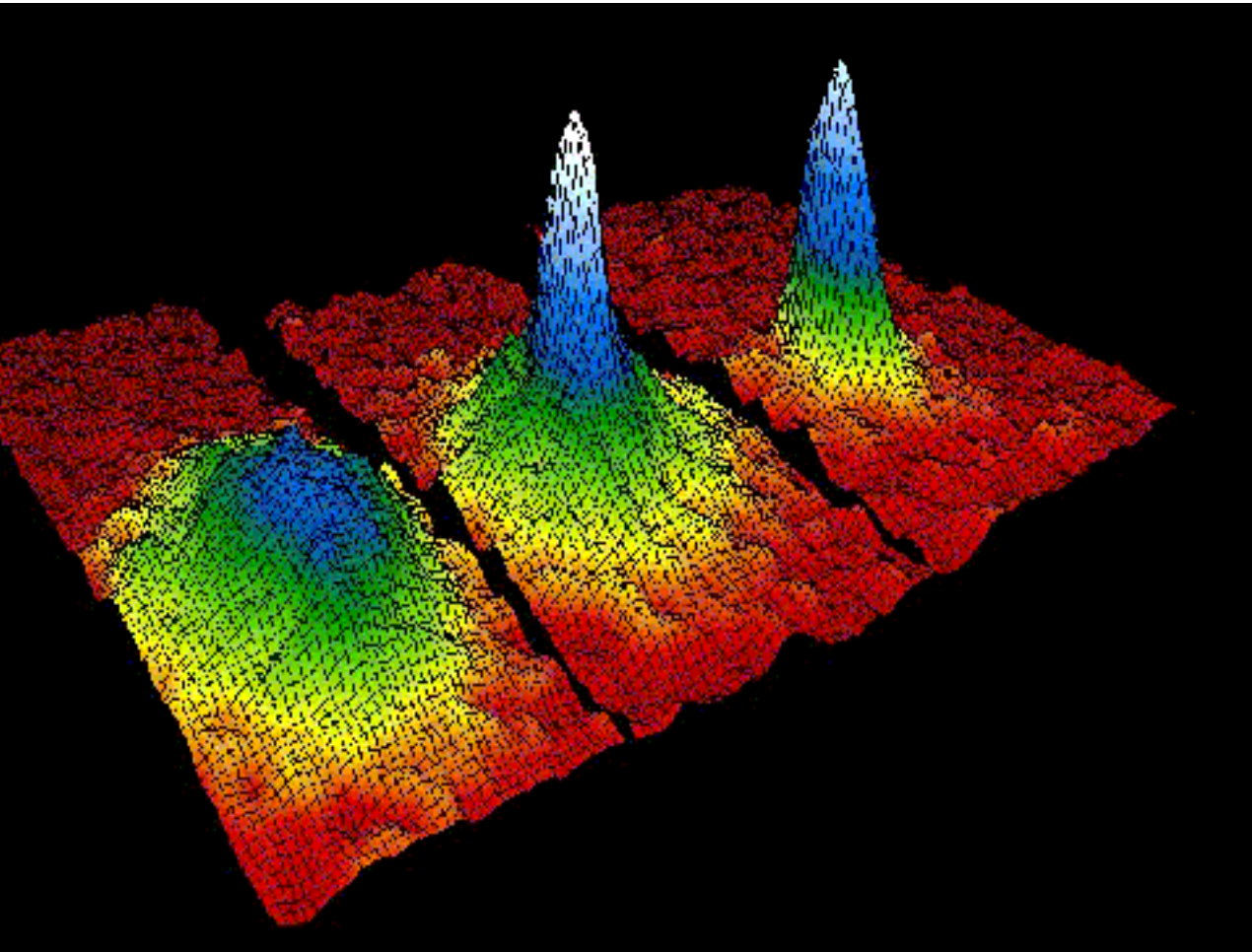

1000 atoms in ground state of magnetic trap.

Remark:
Metastable systems
The true ground state of Rb at $1 \mu\text{K}$ is a piece of solid

Science, 269, 198 (1995)
J. Anderson, E. Cornell and C. Wieman

+ Sodium, Lithium, Hydrogen, Potassium
Helium (2s state), Cesium, Ytterbium

Bimodal distributions

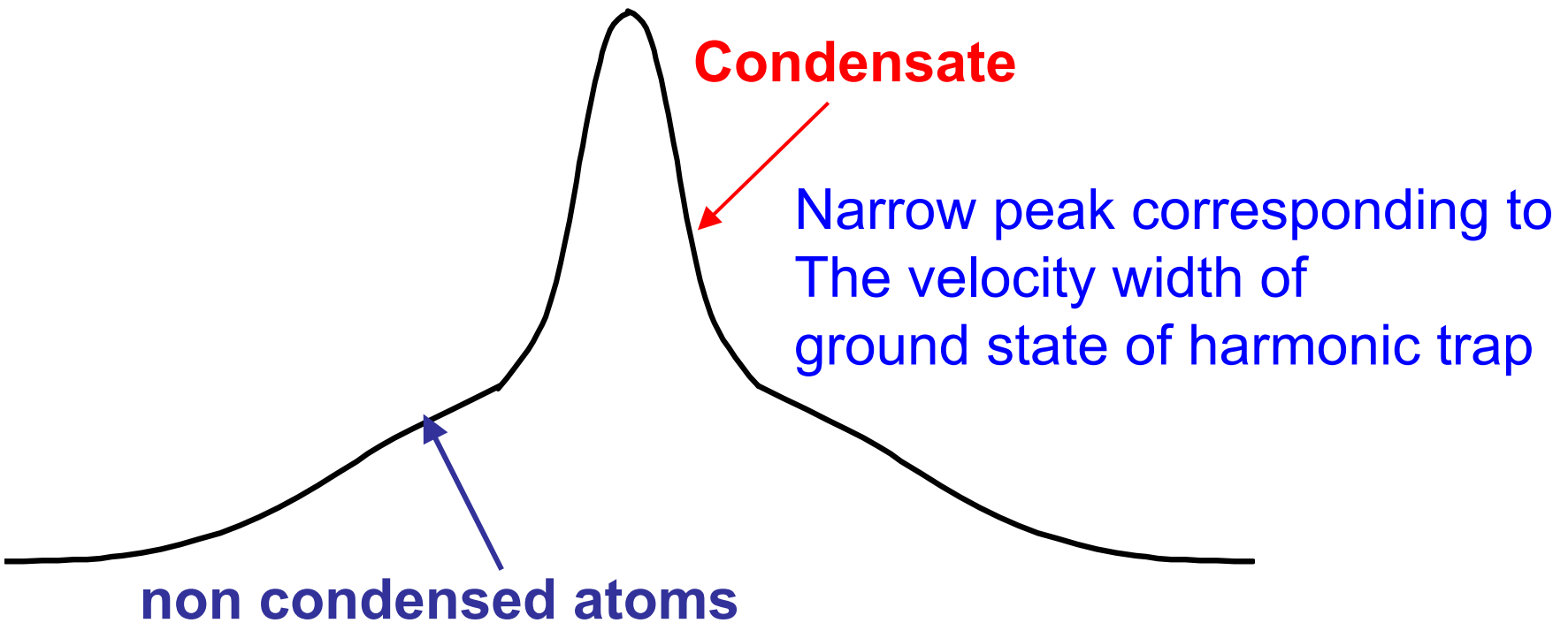

Thermal atoms in excited states: broader distribution

Condensate signature

A few millions atoms in anisotropic magnetic trap

$$T > T_c$$

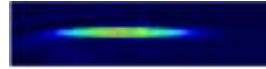

Time of flight

$$T < T_c$$

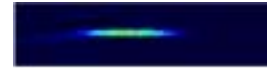

0,5 to 1 μK

100 μm * 5 μm

Boltzmann
Gas

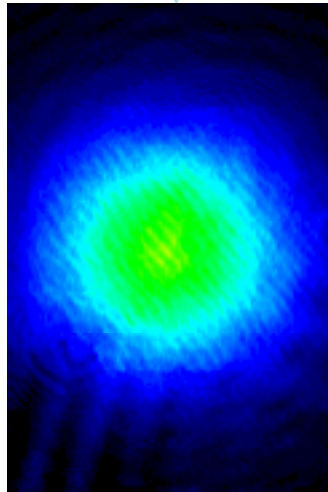

isotropic

condensate

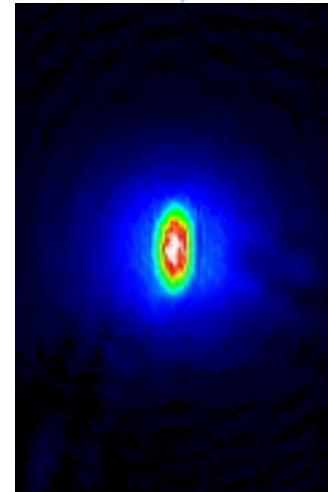

anisotropic

$$\frac{1}{2}mv_i^2 = \frac{1}{2}kT$$

$$\frac{1}{2}mv_i^2 = \frac{1}{4}\hbar$$

without
interactions

Coherence of Bose-Einstein condensates

Young slit experiment, Munich

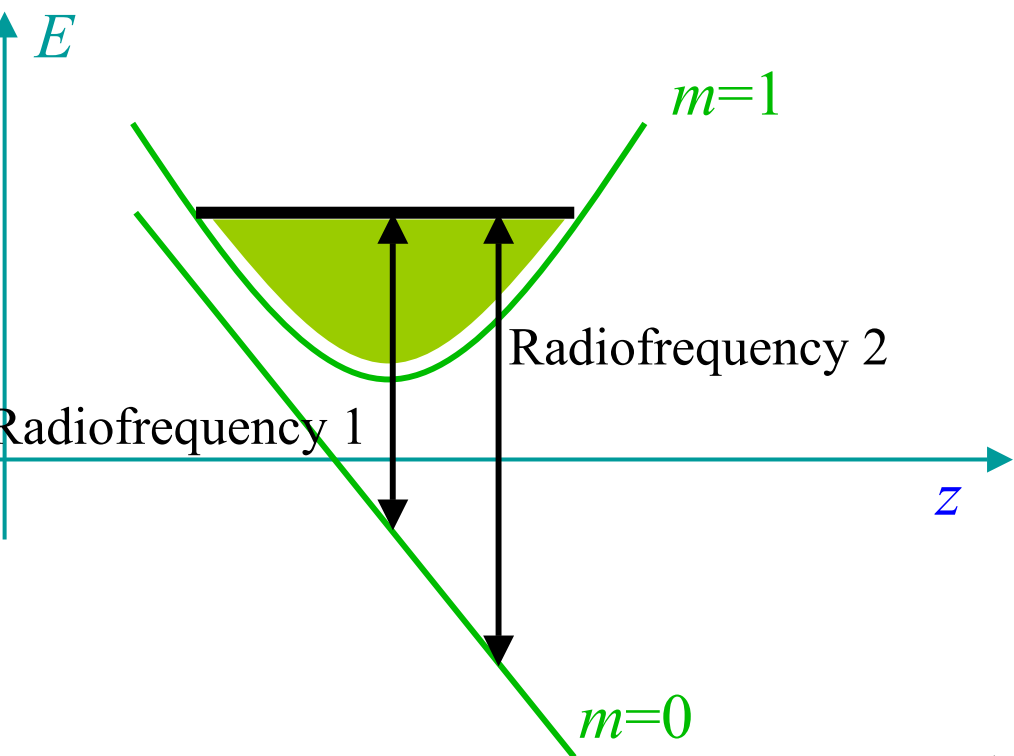

High contrast reveals
macroscopic occupation
of single quantum state

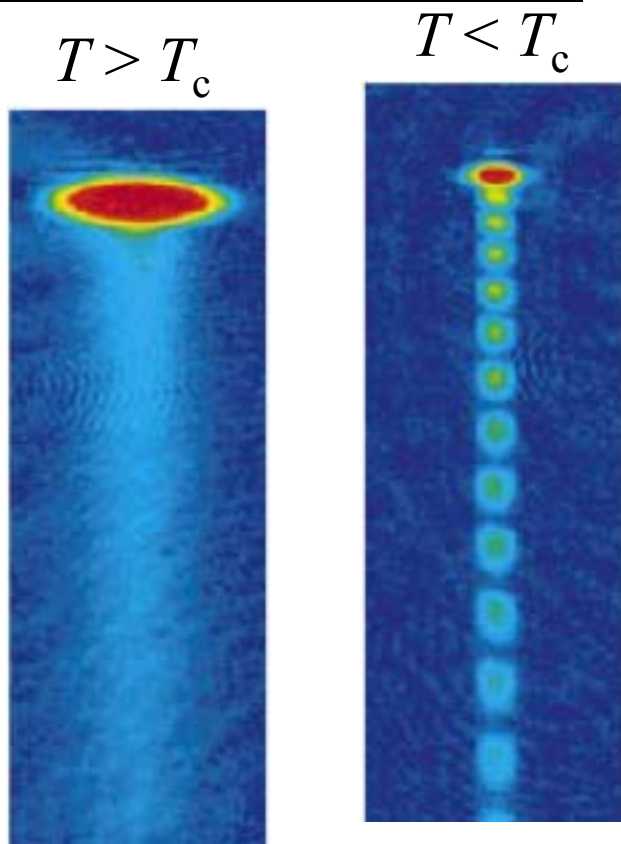

$$n_{out}(z) = \left| \psi_{out}(z - z_1) + \psi_{out}(z - z_2) \right|^2$$

$$\propto \frac{1}{\sqrt{z}} \left\{ 2 + 2 \cos \left(q\sqrt{z} + (\omega_1 - \omega_2)t \right) \right\}$$

$$q = m(z_2 - z_1) \sqrt{2g} / \hbar$$

Atom lasers

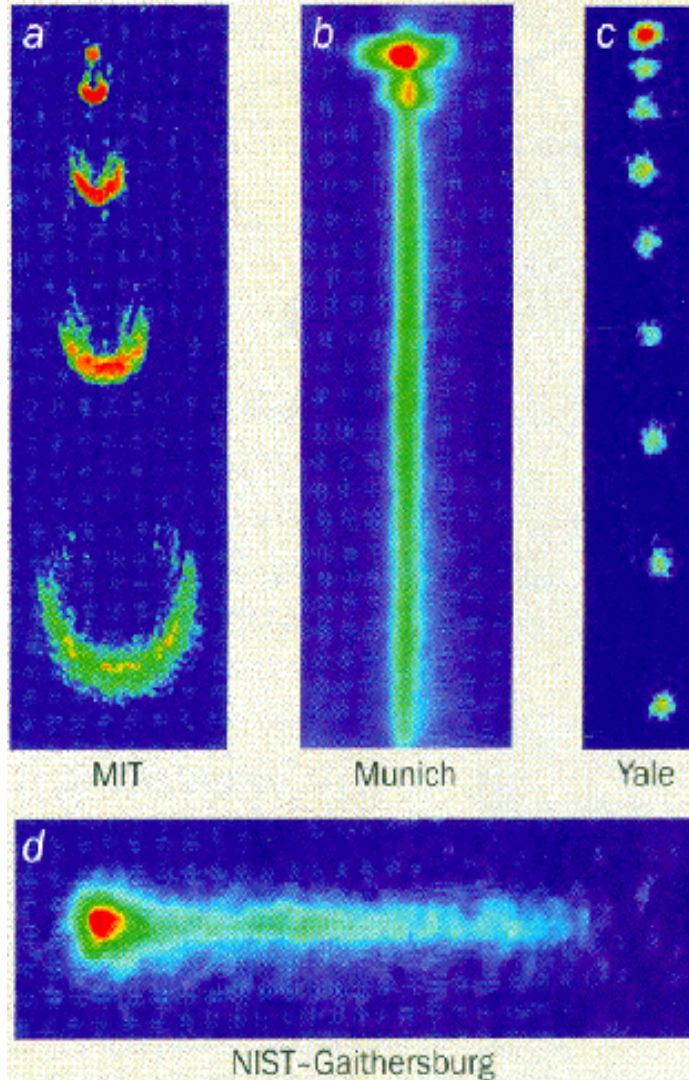

But limited flux:
less than 10^6 /second

Towards a continuous atom laser

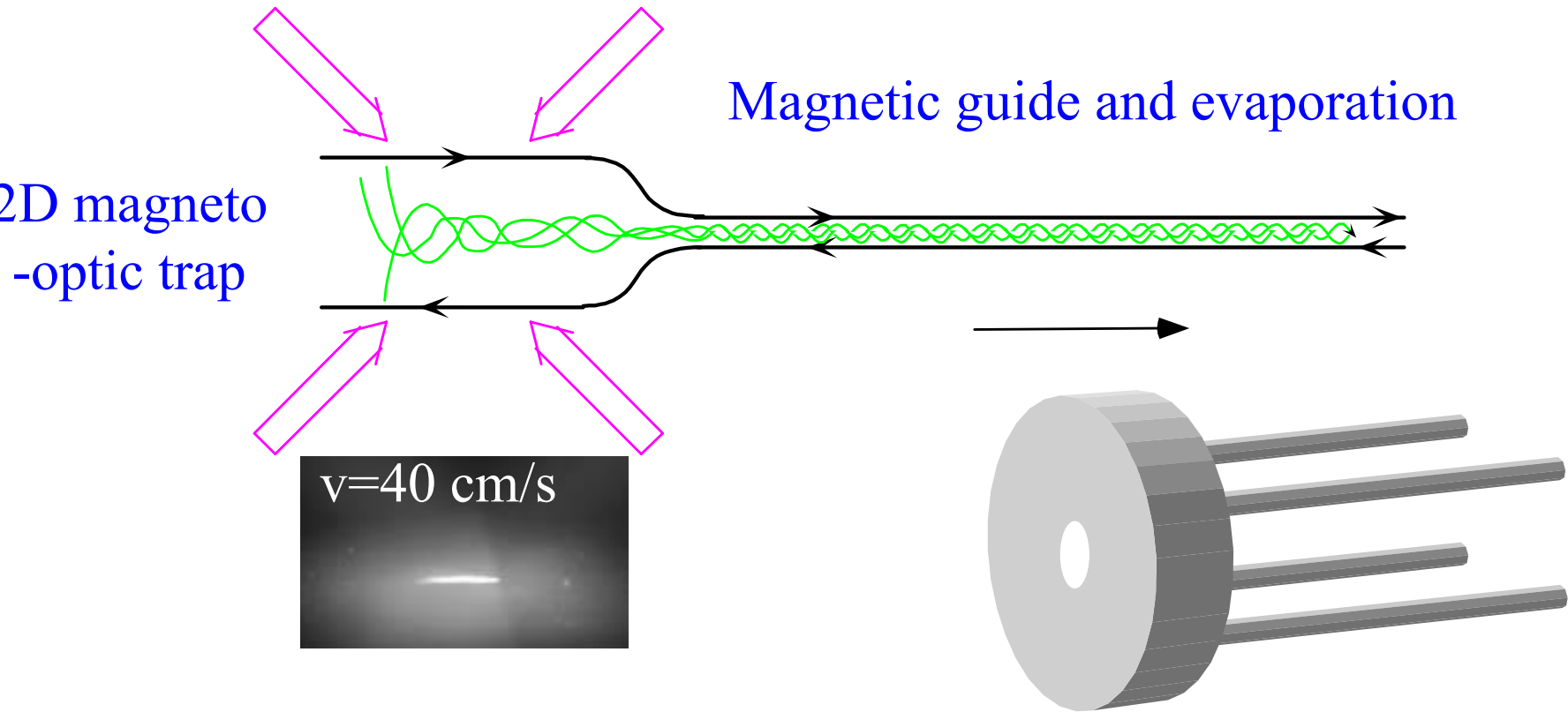

Expected flux: 10^7 condensed atoms /second

Condensates on a chip

All wires for magnetic trapping and manipulation are integrated on a chip with a few cm^2 area



Gold wires ($10\mu\text{m}$) on silicon substrate

Greatly simplifies vacuum requirements, power requirements,
But so far, condensates with small numbers (a few 10^4)
Application to atom interferometry on a chip
Quantum sensors in space
See C. Bordé lectures

Control of interactions within a condensate

Gross-Pitaevski equation :

$$\left(-\frac{\hbar^2}{2m} \Delta + V(\vec{r}) + Ng |\psi(\vec{r})|^2 \right) \psi(\vec{r}) = \mu \psi(\vec{r})$$

$$g = \frac{4\pi\hbar^2 a}{m}$$

a : scattering length

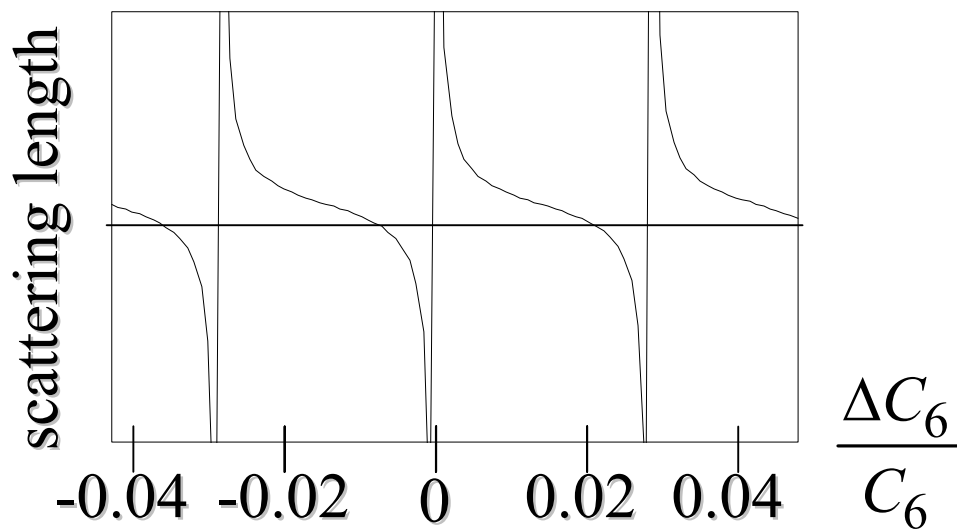
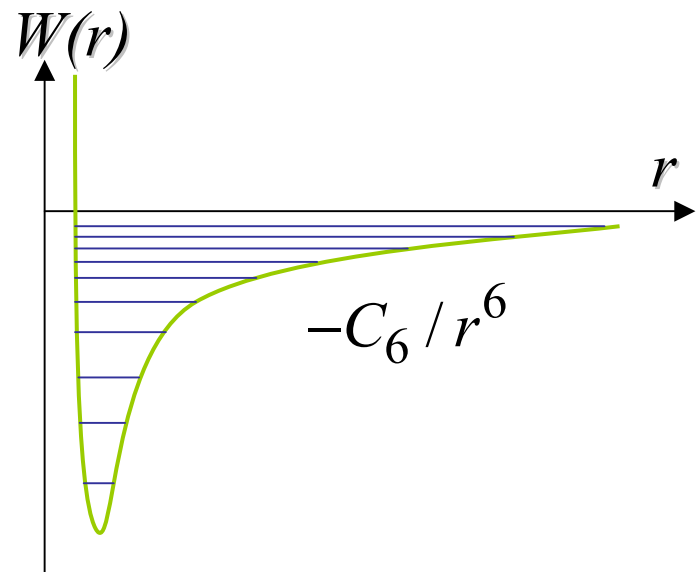

$|a|$ varies typically between 1 and 100 nanometers (Bohr radius : 0.05 nm)

The scattering length: a

- At very low temperatures one parameter is sufficient to describe atomic interactions: the scattering length a
- Scattering cross section: $\sigma = 4 \pi a^2$
(for non identical particles)
- Mean field of a gas with density $n(r)$

$$U(r) = \frac{4 \pi \hbar^2 n(r) a}{m} \quad \text{NL GPE}$$

- Example: BEC in dependence of mean field

Ideal gas: $a=0$

Repulsive: $a>0$

Attractive: $a<0$

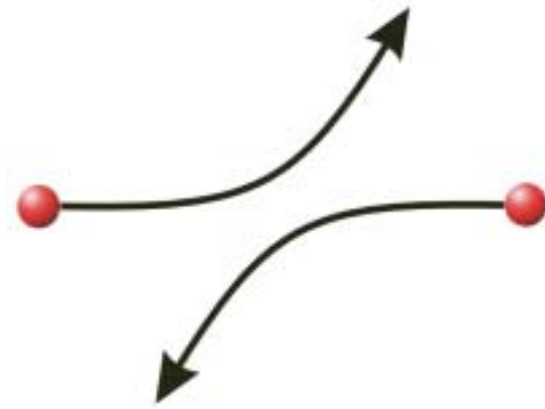

3D gas

1D gas

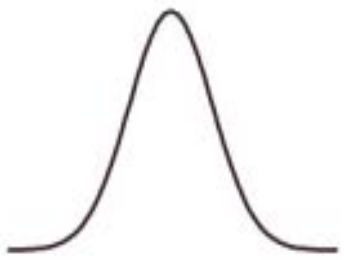

Gaussian



Parabola

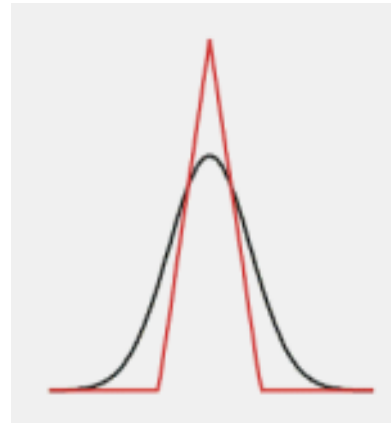

Collapse (for $N > N_{crit}$)

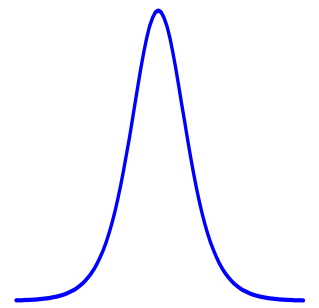

Soliton

Solitons

- Propagation of a wave without deformation over large distances
Dispersion counterbalanced by non linear interaction
- Discovered in 1834 by Scott Russell in water

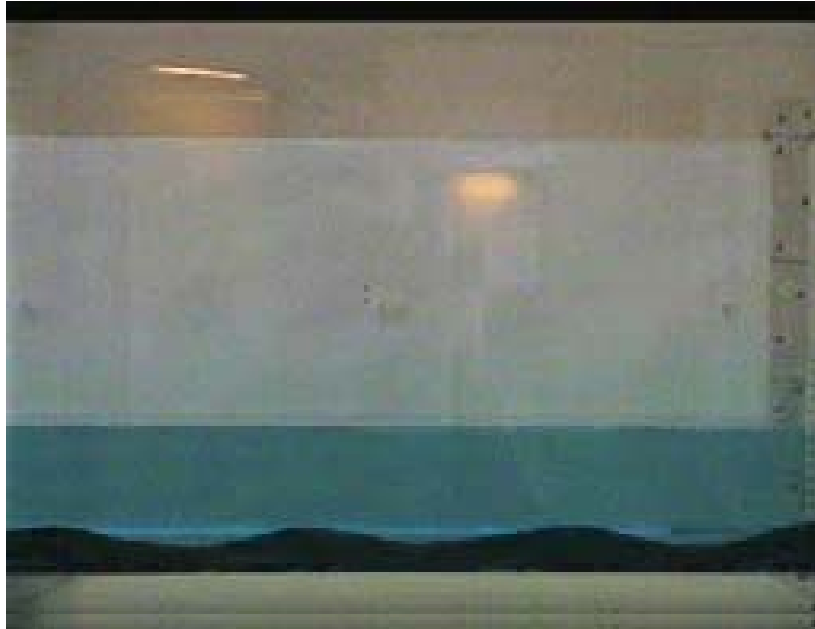

- Used in optical fibers for telecommunications

Non-linear Schrödinger equation
Equivalent to Gross Pitaevski equation



Manipulating interactions : soliton formation

One prepares a lithium 7 condensate with repulsive interaction and place it in a quasi-1D geometry (ENS):

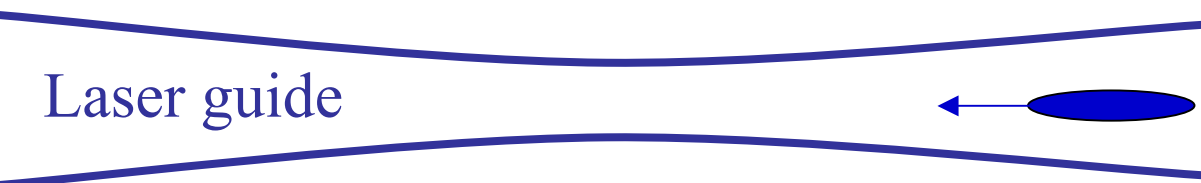

$$\hbar\omega_{\perp} \ll k_B T, \mu$$

One switches interactions towards $a=0$ (ideal gas) or $a<0$ (attractive)

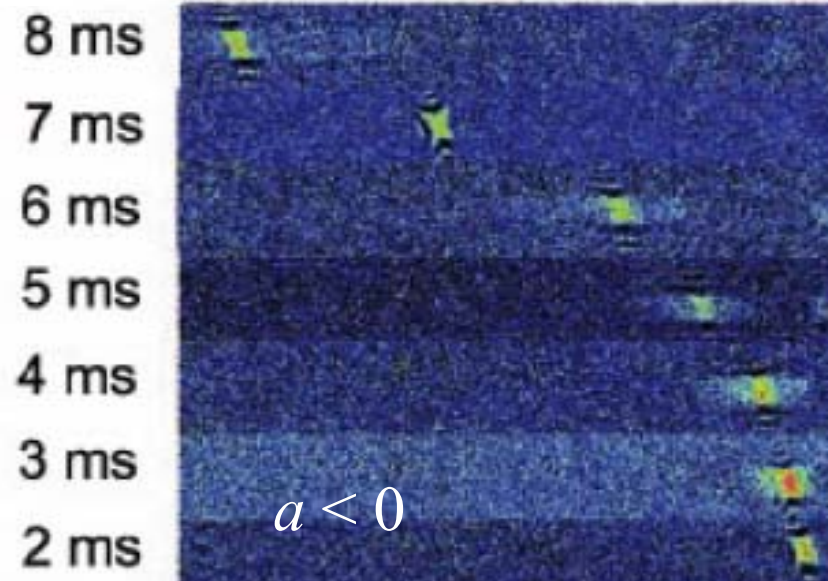
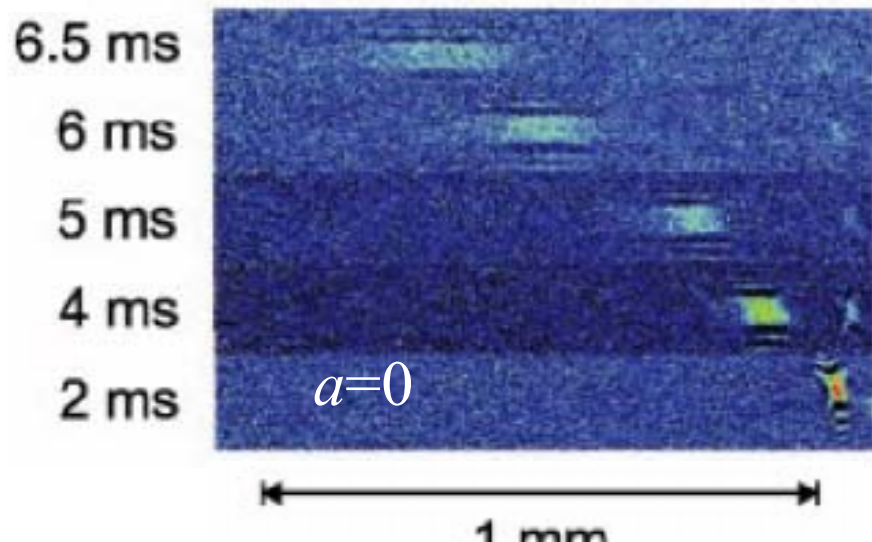

Rotating condensate from single vortex to vortex lattices

As for liquid helium, existence of a critical rotation velocity

ENS



*Just below
The critical
frequency*



*Just above
critical
frequency*

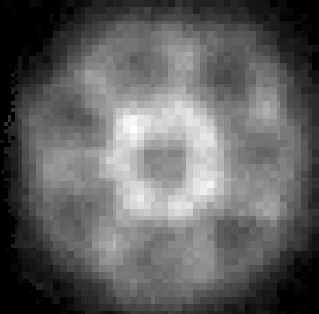

*Notably
above critical
frequency*

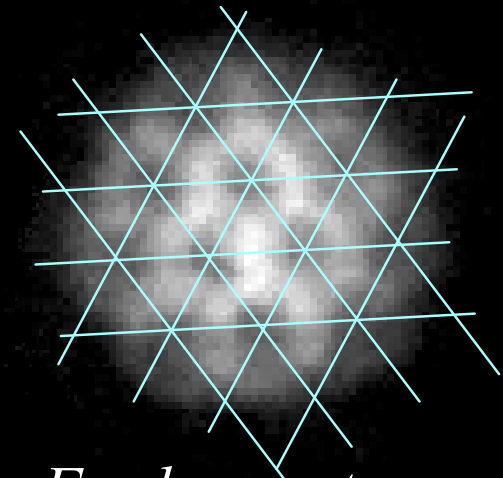

*For large atom
Numbers:
Abrikosov lattice*

Science

23 February 2001

Vol. 291 No. 550
Pages 1435-1650

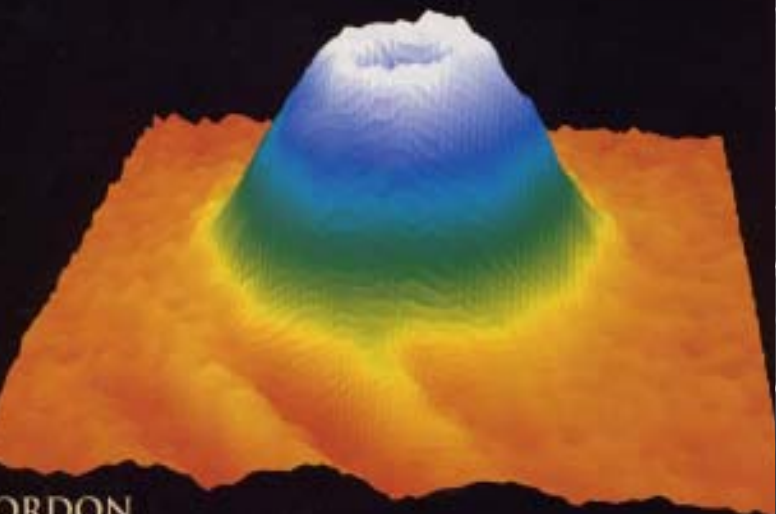

ORDON
RESEARCH
ONFERENCES

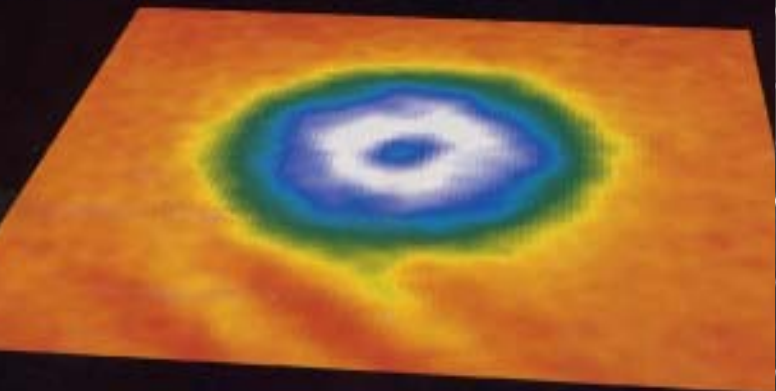

AMERICAN ASSOCIATION FOR THE ADVANCEMENT OF SCIENCE

nature insight

Reprinted from Vol. 416, no. 6877, 14 March

ultracold matter

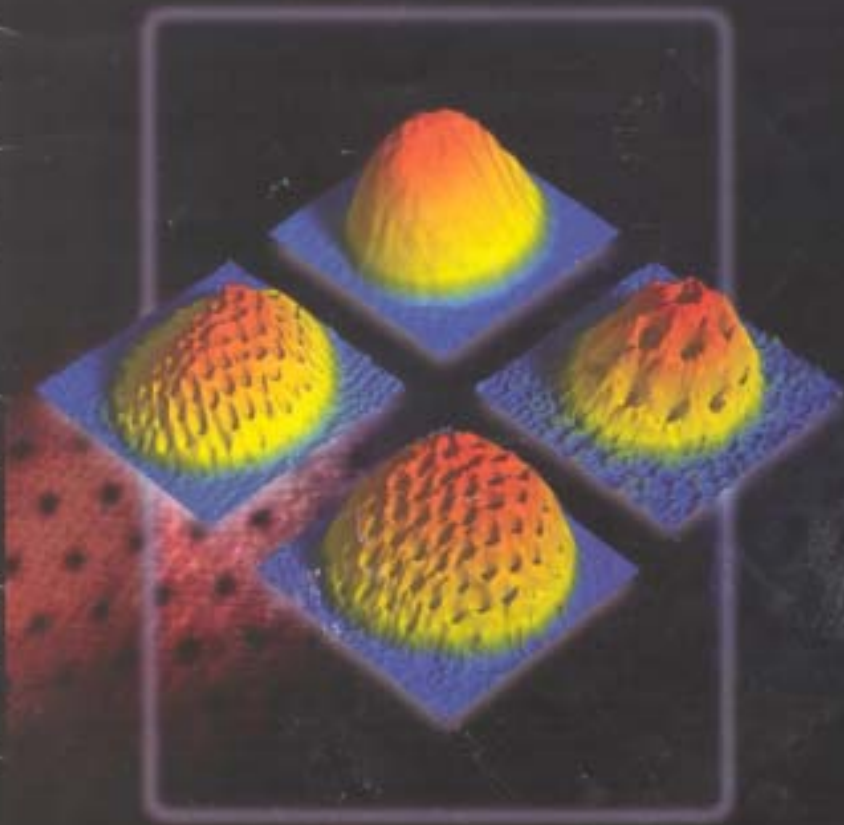

Perspectives

Exploit the quantum coherence:

Can one build a continuous atom laser with high output flux?

Atom interferometry, metrology with coherent matter waves
lithography

Study of these new macroscopic quantum systems

low dimension BEC : 1D or 2D (Tonks gas, quantum Hall effect)

Molecular BEC

Fermions: towards superfluid transition in Fermi systems

FURTHER READING

- **BOSE-EINSTEIN CONDENSATION IN ATOMIC GASES**, Proceedings of the International School of Physics « Enrico Fermi », Course CXL, ed. **M. Inguscio, S. Stringari, C.E. Wieman**, IOS Press, 1999.
- **LASER MANIPULATION OF ATOMS AND IONS**, Proceedings of the International School of Physics « Enrico Fermi », Course CXVIII, ed. **E. Arimondo, W.D. Phillips, F. Strumia**, Elsevier Science, 1992.

